

TECHNICKÝ LIST

STREŠNÝ ŽLAB HRANATÝ [s=0,55]

PH-PZH

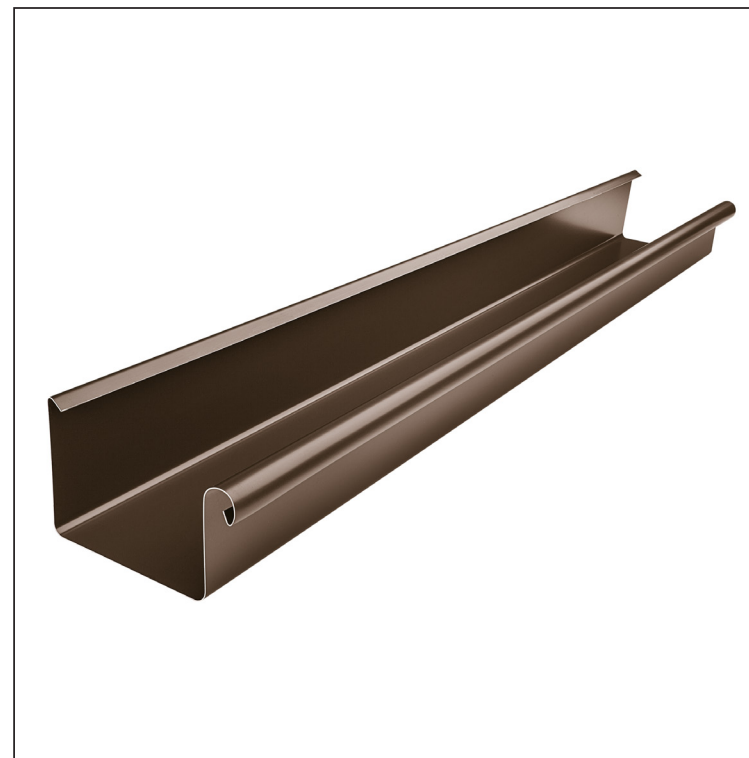
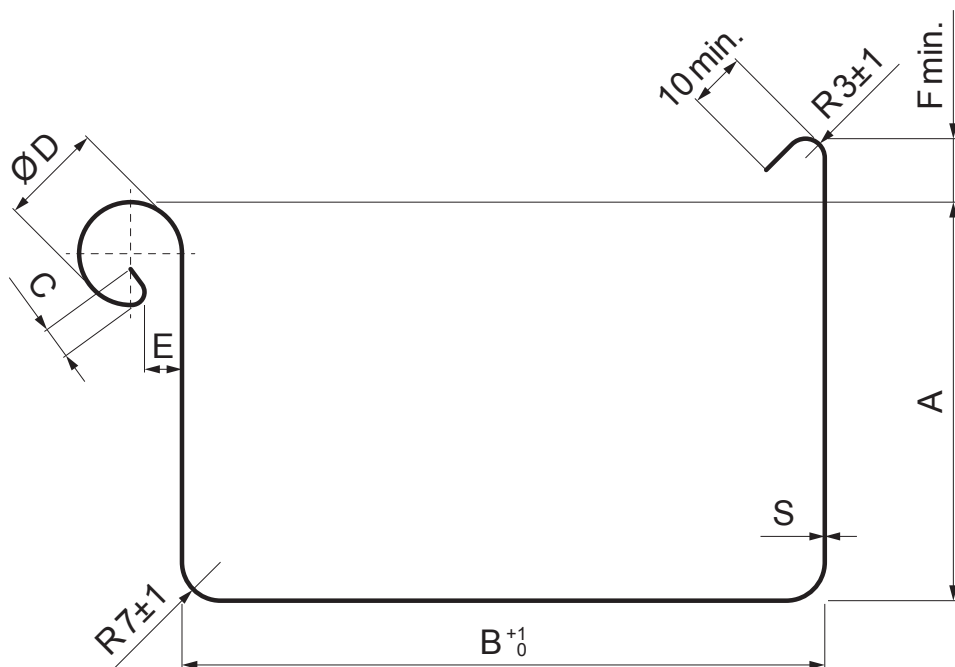

TM Pozink lakovaný – Testa di Moro – RAL 8028

Rozmery [mm]							
Menovitá veľkosť	S	A	B	C	ØD	E	F min.
200	0,55	42	70	5	16	5	8
250	0,55	55	85	7	18	5	10
333	0,55	75	120	7	20	6	11
400	0,55	90	150	9	22	6	11
500	0,55	110	200	9	22	6	11

INDEX	ZMENA	DATUM	PODPIS	KJG QUALITY®	Scan code for 3D model	
ZN. MAT.	ROZM.-POLOT	T.O.	HMOTNOSŤ kg			
POM. ZAR.	VYPR. Ing. Kluska M.	POZN.	STARÝ V.	Č.V.		
TECHNOL.	TECHNOL.	STARÝ V.	Č.V.			
NÁZOV	Strešný žlab hranatý [s=0,55]		Počet listov	PH-PZH	List	

Technické zmeny vyhradené