

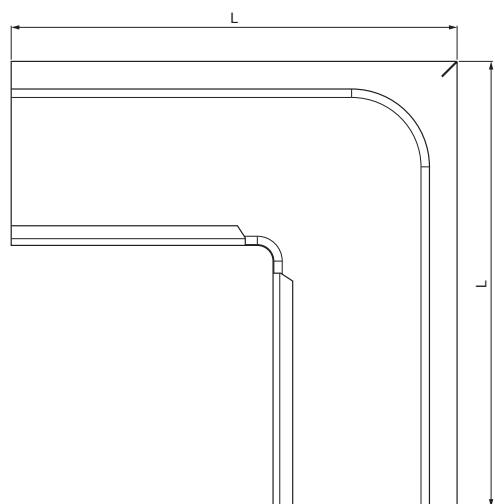

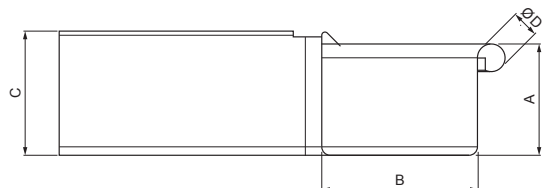

TECHNICKÝ LIST

# ŽLABOVÝ ROH VONKAJŠÍ HRANATÝ

# PH-PRAH



**TM** Pozink lakovaný – Testa di Moro – RAL 8028

INDEX	ZMENA	DATUM	PODPIS				
ZN. MAT.							T.O.
ROZM.–POLOT							
POM. ZAR.					STN		TR.Č.
VYPR.	Ing. Kluska M.				POZN.		Č.POZÍCIE
PRESK.							
TECHNOL.		TECHNOL.			STARÝ V.		Č.V.
NÁZOV	Žlabový roh vonkajší hranatý				Počet listov	PH-PRAH	List 

Rozmery [mm]					
Menovitá veľkosť	A	B	C	ØD	L
200	42	70	50	16	250
250	55	85	65	18	300
333	75	120	85	20	300

Technické zmeny vyhradené



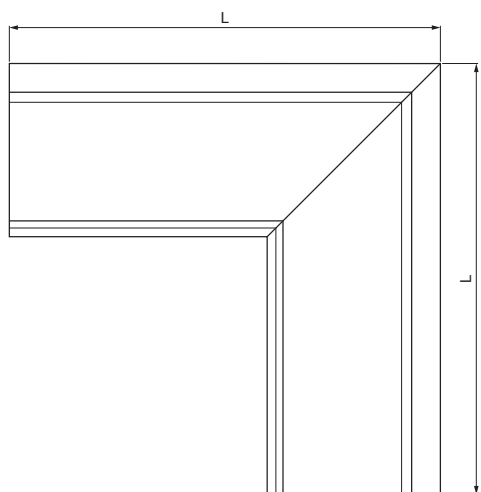
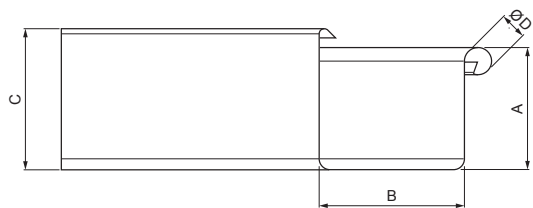

TECHNICKÝ LIST

# ŽLABOVÝ ROH VONKAJŠÍ HRANATÝ

# PH-PRAH



**TM** Pozink lakovaný – Testa di Moro – RAL 8028

INDEX	ZMENA	DATUM	PODPIS			
ZN. MAT.	T.O.		HMOTNOSŤ kg			
ROZM.–POLOT			STN	TR.Č.		
POM. ZAR.			POZN.	Č.POZÍCIE		
VYPR.	Ing. Kluska M.		STARÝ V.	Č.V.		
PRESK.						
TECHNOL.	TECHNOL.					
NÁZOV	Žlabový roh vonkajší hranatý			Počet listov	PH-PRAH	List 

Rozmery [mm]					
Menovitá veľkosť	A	B	C	ØD	L
400	90	150	100	22	400
500	110	200	121	22	400

Technické zmeny vyhradené